

evo

RemRest™

Tiers 1-3

900 Series

Patient Manual



CAUTION: USA Federal law restricts this device to sale by or on the order of a physician.

Table of Contents

SIZE

4.7" H X 8.6" W X 9.4" D
11.9cm H x 21.8cm W x
23.9cm D

WEIGHT

<5lb 2.3kg

PRESSURE RANGE

3.5 CMH₂O TO 20 CMH₂O

RAMP TIME

5 TO 50 MINUTES

ELECTRICAL REQUIREMENTS

100-240V~, 50/60 HZ or
12 VDC, 40 Watts

OPERATING TEMPERATURE RANGE

41°F to 104°F (5°C to 40°C)

STORAGE AND TRANSPORTATION TEMPERATURE RANGE

-4°F to 140°F (-20°C to 60°C)

STORAGE AND TRANSPORTATION HUMIDITY RANGE

10% TO 95% RH
non-condensing

SOUND LEVEL

<30 dba (@10cmH₂O,
1 meter from CPAP)

Specifications	2
Introduction	3
IEC Symbols	4
System Components	5
Instructions for Use	6
Save These Instructions	7
Accessories	15
RemRest Care	16
Troubleshooting	18
Travel Information	20
Safety	21
Warranty	22

In 1993, the National Commission on Sleep Disorders Research stated that as many as 18 million Americans may have signs and symptoms of Obstructive Sleep Apnea (OSA). OSA is a condition where the upper airway relaxes during sleep causing the airway to obstruct. Apnea is a word meaning "without breath." People diagnosed with OSA stop breathing repeatedly during sleep which can result in extreme exhaustion and damage to vital organs.

HOW DOES THE REMREST HELP?

The RemRest is a CPAP (Continuous Positive Airway Pressure) device which provides constant non-invasive air pressure to your upper airway causing the airway to stay open. In doing so, you are able to sleep with no interruption allowing your body to rest and regenerate. Small, adjustable, lightweight and quiet, the RemRest is our contribution to reaching your dreams.

IEC Symbols

Equipment Classification with respect to protection from electric shock: **Class II**

Degree of protection from electric shock: **Type BF**

Degree of protection against ingress of liquids: **Ordinary**

Equipment not suitable for use in the presence of flammable anaesthetic mixture with air or with nitrous oxide.

Mode of operation: **Continuous**



Attention, consult accompanying documents



Type BF equipment



Direct Current



Alternating Current

System Components

FRONT

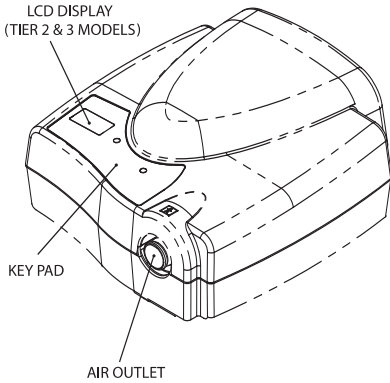

BACK

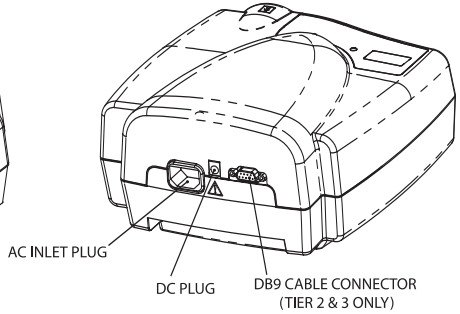

SIDE

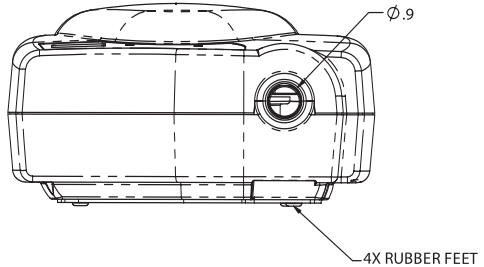

BOTTOM
INLET FILTER

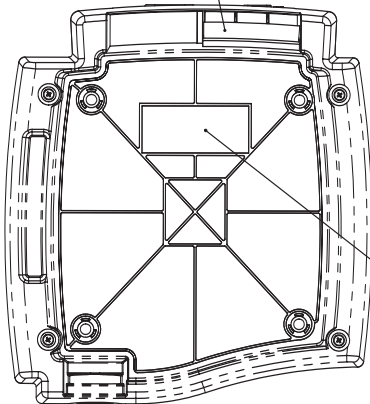

SERIAL NUMBER LABEL

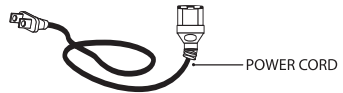

AUTO ADAPTER

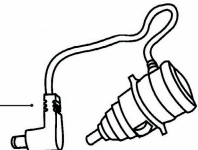

Instructions For Use

IMPORTANT SAFEGUARDS

Follow all basic safety precautions. Please read instructions before using. Precautions are not limited to the safety information provided. Important information is highlighted as indicated:

WARNING

Important safety information for hazards that might cause serious injury.

CAUTION

Important information to prevent damage to the device.

NOTE

Information requiring special attention.

Save These Instructions

The RemRest system consists of a CPAP flow generator, tubing and a nasal interface. Other accessories may be used and are available as needed from your care provider. Comfortable fit is very important. Please discuss with your care provider to determine the best nasal interface that will meet your needs.

WARNING

Do not under any circumstances plug any vent holes on your mask. These are for proper exhaling and plugging them might cause carbon dioxide buildup. This warning does not pertain to any capped holes on your mask. These are for diagnostic purposes and may remain plugged.

WARNING

This CPAP unit should be used only with masks (and connectors) recommended by the manufacturer of the CPAP machine, your physician, or respiratory therapist. A mask should not be used unless the CPAP is turned on and operating properly.

Explanation of the Warning: This CPAP unit is intended to be used with special masks (or connectors) which have vent holes to allow continuous flow of air out of the mask. When the CPAP unit is turned on and functioning properly, new air from the CPAP machine flushes the exhaled air out through the mask vent hole. However, when the CPAP machine is not operating, enough fresh air will not be provided through the mask, and exhaled air may be rebreathed. Rebreathing of exhaled

WARNING

This device is not suitable for use in the presence of a flammable anaesthetic mixture with air or with nitrous oxide.

WARNING

This is not intended for use as a life supporting or life sustaining device. It is intended for use on spontaneously breathing adults.

WARNING

All settings of your RemRest are to be adjusted by authorized personnel. Settings are the result of physician supervised diagnosis and must not be changed without physician authorization.

air for longer than several minutes can in some circumstances lead to suffocation. This warning applies to most models of CPAP units.

CAUTION

At low CPAP pressures, the flow through the exhalation port may be inadequate to clear all exhaled gas from the tubing. Some rebreathing may occur. This warning applies to devices with rebreathing testing which demonstrates that rebreathing may occur at low pressures within the operating pressure range of the device.

CAUTION

The air flow for breathing produced by this device can be as much as 4°F higher than the temperature of the room. Caution should be exercised if the room temperature is warmer than 90°F. (This caution applies to devices in which the temperature of the output of the device is more than 3°F above ambient under typical test conditions.)

REMREST TUBING SET-UP

Smooth-bore tubing is designed to deliver air pressure to your nasal interface. Attach one end of your tubing to the RemRest air outlet. The other end of the tubing is used for the nasal interface. See diagram on page 5. When humidifier or oxygen equipment is used with the RemRest system, please follow the user instructions provided with the humidifier or oxygen equipment to set up the system. For best results, it is recommended you use the RemRest Heated Humidifier with this device.

RemRest Flow Generator Operation

- Place the RemRest device on a flat, sturdy surface with the back of the unit away from heating vents, radiators, curtains and other objects that could restrict air intake.
- Secure the mask, connect the tubing, and prepare any accessories you might use prior to operation of the RemRest device.

It is recommended that the device be left plugged in when not in use. This is especially helpful for Tier 2 and 3. Tier 2 does not have a battery and therefore only “remembers” plugged in time with regards to time used and time plugged in. Tier 3 has an internal battery and therefore will “remember” all of its times without being plugged in. However, it will save the battery if the unit remains plugged in when not being used, i.e. during the day.

RemRest Tier 1

There are two options to provide power to the CPAP: AC or DC power.

1. For AC Power, plug one end of the AC power cord into the AC inlet plug located on the back of the RemRest device. Plug the other end into the wall socket. Go to Step 3.
2. If using the DC power cord with auto adapter for operation of the RemRest in a motor vehicle or recreational vehicle, insert the plug into the DC jack located on the back of the CPAP and plug the other end into the vehicle’s 12V DC outlet.

NOTE

The device will draw a small amount of power when plugged in but not “On”.

3. The two green lights (on/off light and ramp light) will turn on for two seconds then will remain off until the motor/blower is turned on and/or the ramp function is turned on. If the ramp function was used the last time the device was operated, then the ramp light will stay on.

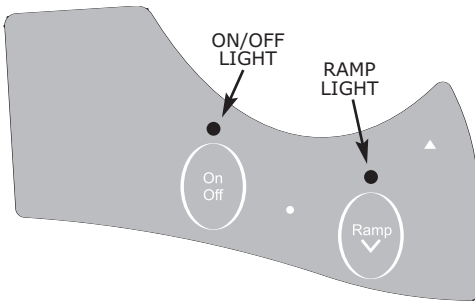

4. To turn on a Tier 1 device, press the on/off button. The on/off light will turn on and the CPAP device will accelerate to its prescription air pressure setting. If the ramp function is turned on (the ramp light is on), then the CPAP device will reach the prescription air pressure setting according to the preset ramp time.

Your physician may have prescribed a specific ramp time. In this case, do not attempt to adjust the ramp setting or operating the unit without the ramp function turned on without consulting your physician.

5. If the ramp function is not already set, simply pushing the ramp button on once the unit is running will not start the ramp function. To initiate the ramp function:
 - If the device motor is running, turn off the device by pushing on/off button (ramp light and on/off light turn off)
 - Push the ramp button on (ramp light turn on)
 - Turn ON the device by pushing on/off button (ramp light and on/off light on). The CPAP will start at the prescribed low setting and accelerate through the ramp time to prescribed pressure setting.
6. To turn off the ramp function: While the unit is running, push the ramp ON/OFF button. The ramp light will go out and the unit will go to the prescription pressure setting. When the device is turned on again, the RemRest will accelerate to the prescription setting without the ramp.
7. Turn OFF the device (ramp light and on/off light turn off) by pressing the ON/OFF button.

RemRest Tier 2 & Tier 3

There are two options to provide power to the CPAP: AC or DC power.

1. For AC Power, plug one end of the AC power cord into the AC inlet plug located on the back of the RemRest device. Plug the other end into the wall socket. Go to Step 3.
2. If using the DC power cord with auto adapter for operation of the RemRest in a

- motor vehicle or recreational vehicle, insert the plug into the DC jack located on the back of the CPAP and plug the other end into the vehicle's 12V DC outlet.
3. The green light (on/off light) will turn on for two seconds then will remain off until the motor/blower is turned on. The LCD will also turn on completely (as shown in Symbols Definition section on page 13) for 2 seconds and will then switch to display the prescription pressure. The display will illuminate and show the pressure setting and icons based on the last settings saved. If the ramp function was used the last time the device was operated, then the ramp icon will be illuminated on the LCD indicating the ramp mode is still active. The display will show the prescription pressure setting in cmH₂O. The  PRES icon will be on.

NOTE:

For Tier 3 only, the  TIME icon on the LCD may be flashing. See the AUTO MASK CHANGE section on page 15.

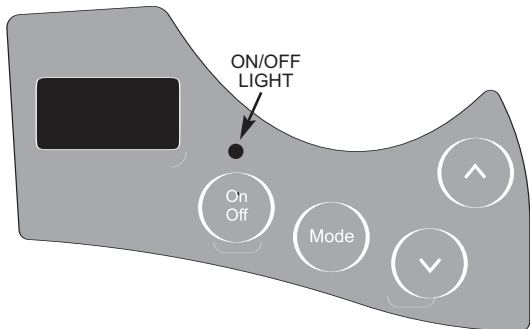









NOTE

Running the RemRest off your vehicle battery (12V DC) without the engine running may drain the battery.

SYMBOL DEFINITIONS





-  **LOW** Used in technician/dealer mode only
-  **HI** Used in technician/dealer mode only
-  **TIME** Used in the technician/dealer mode only
-  **USE** Used in the technician/dealer mode only
-  **RAMP** Icon will flash during ramp setting or will stay on once ramp is set and the ramp mode is in use
-  **RUN** The display will show the time the motor/blower has been running. May only be reset in the dealer/technician mode
-  **PRES** The display will show the prescription pressure setting
-  **HUMD** Not currently available.

4. To turn on the device, press the on/off button. The on/off light will turn on and the CPAP device will accelerate to its prescription air pressure setting.
 - If the ramp function is not turned on, then the Ramp icon will not be shown on the LCD and the prescription will be shown.
 - If the ramp function is turned on, then the RemRest will reach the prescription air pressure setting according to the preset ramp time.

- In the ramp mode, the display will show the increasing pressure until the prescription pressure is reached.

Your physician may have prescribed a specific ramp time. In this case, do not attempt to adjust the ramp setting or operating the unit without the ramp function turned on without consulting your physician.

5. If the ramp function is not already set, changing the ramp setting to "ON" while the CPAP device is running will not start the ramp function. To initiate the ramp function:
 - Press the mode button once, the  ramp icon should flash.
 - Press the \wedge up arrow or \vee down arrow to toggle the setting on and off. The display will show ON or OFF to indicate whether the ramp function is on or off.
 - If the device motor/blower is running, turn OFF the device.
 - Turn ON the device. The CPAP will start at the prescribed low setting and accelerate through the ramp time to the prescribed pressure setting.
6. To view the total running time of the motor/blower, press the mode button a second time or until the  TIME icon is on. The running time in hours will show on the display. Press mode again to return the display to the prescribed pressure setting.

7. To view the “data code”, push and hold the MODE button for three seconds, a code will show up on the display for five seconds and the on/off light will flash. No other icons will turn on. After five seconds, the display will return to the prescribed pressure setting and the on/off light will stop flashing.
8. Turn OFF the device (the on/off light will turn off and the motor/blower will stop running). The display will remain on, if the device remains plugged in.

Accessories

A wide variety of accessories such as masks, headgear, tubing, and humidifiers are available from EVO and can be purchased through your local care provider. Instructions on how to assemble the purchased accessories will be found in the accessory package.

AUTO MASK CHANGE

For Tier 3 only, the  TIME icon on the LCD will flash after 90 days. Please contact your care provider for further assistance with obtaining a new mask.

RemRest Care

WARNING

Make sure to unplug the device from the wall outlet or DC power source before cleaning as failure to do so may cause electric shock.

CAUTION

Never place or submerge this unit under water or place near a water source of any kind. Do not allow liquids to enter into this device. Doing so may result in device damage.

CAUTION

Do not clean RemRest device with alcohol or alcohol based products.

REMREST CLEANING

To clean the RemRest device, turn OFF the unit and unplug it from the power source. Using a damp cloth, wipe the unit clean making sure no liquids enter the device itself. Allow the unit to completely dry prior to using.

REMREST INLET FILTER

The RemRest filter is located on the back of the device and is reusable. To make sure your device continues to provide optimum performance, check your filter weekly and clean the filter once per month (or sooner if dirty).

To clean the filter, remove the filter from the unit and wash it in warm water until the water runs clear. Allow the filter to completely air dry. Once the filter is dry, return it to its housing.

MASKS, NASAL INTERFACES, TUBING AND HEADGEAR

Consult the user instructions provided with the accessories to determine the recommended cleaning method. Otherwise, these items may be washed as needed. To clean, remove the tubing and headgear from the nasal interfaces. Using a solution of warm water and mild dishwashing detergent such as Dawn™, wash each item individually, rinse with clean, warm tap water and allow the accessory to air dry before using. Hang the tubing vertically to allow the water to drain and dry completely.

CAUTION

Do not place masks, tubing, headgear or other nasal interfaces in the dishwasher. Some automatic dishwashing soaps contain ingredients which may damage these items. Alcohol or alcohol based cleaners may also damage these accessories.

SYSTEM SERVICE

Do not attempt to open or remove the outer covers of the CPAP as there are no user-serviceable internal components. Do not attempt to repair this unit on your own as this may cause further damage and will void the warranty. If service is required, have your care provider return this device to an authorized EVO service center.

Troubleshooting

Problem	Possible Causes	Remedies
Unit will not run	Unit not plugged into a "live" outlet Power cord not connected properly	Plug unit into a "live" outlet Firmly attach AC or DC cord
No air comes out while the unit is on	Air filter is plugged Air inlet is blocked Flexible hose not connected to device. Unit plugged in but device not turned on	Clean or replace the filter Remove obstruction or reposition the unit so the inlet is not blocked. Connect flexible hose to device. Verify the "green" light is on; if not, push the on/off button
Symptoms of Obstructive Sleep Apnea have reoccurred	Air filter is plugged Incorrect pressure setting Your Obstructive Sleep Apnea conditions have changed	Clean or replace the filter, remove any possible obstructions or reposition the device Contact your care provider Contact your physician, you may need to be retested
Dry or sore eyes	The mask or nasal interface are leaking or headgear adjustment is causing a leak	Readjust your mask, nasal interface or headgear. If problem persists, contact your dealer or care provider

Problem	Possible Causes	Remedies
Irritated skin where mask meets the face	Headgear is too tight	Loosen the headgear
	Poor mask fit	Contact your dealer
	Allergic reaction to mask material	Try a different material or use a barrier between the mask and face. Contact your dealer and physician
Cold nose	Room temperature is too cold — air cools as it travels through the tubing	Raise the room temperature and place tubing under covers to reduce loss of heat
Nasal, sinus, ear pain or runny nose	Nasal reaction to air flow, sinus infection or nasal congestion	Discontinue use. Contact your doctor.
Dryness/burning in throat	Room temperature too high	Decrease room nose or temperature
	Insufficient room humidity	Increase room humidity. If problem persists, contact your dealer regarding humidification devices
Tier 2 & 3 Only: Green Light starts to blink (3 seconds on/1 second off)		The internal data code must be read by the technician. Contact your dealer for further instruction

Travel Information

A carry bag is provided with the RemRest system and is suitable for carrying the unit and most accessories you might have. **This bag is to be used as carry-on luggage only.** Damage might occur to the unit if checked as regular luggage.

RemRest is suitable for operation in most electrical power environments ranging from 100 to 240 Volts of alternating current (VAC), 50 and 60 Hertz or 12V DC when using the DC power cord. Appropriate international plug adapter(s) may need to be used and they differ from country to country. The adapter(s) may be purchased in most retail and/or travel stores. **Besides the plug adapter, no further changes to the machine are necessary.**

OXYGEN SAFETY

Oxygen is a prescription drug and should only be administered under the supervision of a physician.

Oxygen supports combustion. To avoid possible physical injury do not smoke or place the device near any heat source while using your CPAP with oxygen.

WARNING

If oxygen is used with this CPAP machine, the oxygen flow must be turned off when the CPAP machine is not operating.

Explanation of the warning: When the CPAP device is not in operation and the oxygen flow is left on, oxygen delivered into the ventilator tubing may accumulate within the CPAP machine enclosure. Oxygen accumulated in the CPAP machine enclosure will create a risk of fire. This warning applies to most types of CPAP machines.

NOTE

At a fixed flow rate of supplemental oxygen flow, the inhaled oxygen concentration will vary, depending on the pressure settings, patient breathing pattern, mask selection, and leak flow rate. This warning applies to most types of CPAP machines.

ELECTROMAGNETIC SUSCEPTIBILITY

This device meets the requirements of IEC 60601-1-2 which describes requirements for electromagnetic compatibility (EMC) of medical devices. This includes immunity to radio frequency electric fields and electrostatic discharge, in addition to the other applicable requirements of the standard. Compliance with EMC standards does not mean a device has total immunity; certain devices (cellular phones, pagers, etc.) can interrupt operation if they are used near medical equipment.

WARNING

This unit is shipped with a dust cover on the DB9 connector. This cap should be left on except when the connector is in use.

WARNING

This device is not suitable for use in the presence of a flammable anaesthetic mixture with air or with nitrous oxide.

ELECTRICAL SAFETY

Do not submerge this product in water under any circumstances.

Place this product away from the reach of children.

FOLLOW ALL BASIC SAFETY PRECAUTIONS. PRECAUTIONS ARE NOT LIMITED TO THE SAFETY INFORMATION PROVIDED.

Warranty

NOTE

There is no other express warranty. Implied warranties, including those of merchantability and fitness for a particular purpose, are limited to the duration of the express limited warranty and to the extent permitted by law and all implied warranties are excluded. This warranty does not cover providing a loaner device, compensating for costs incurred for device rental, or labor costs incurred in repairing or replacing defective part(s).

EVO warrants the RemRest to be free from defective workmanship and materials for a period of 3 years from the date of purchase. Check with your care provider for more details. This warranty is limited to the care provider. Any defective part or assembly will be repaired or replaced, at the sole discretion and determination of EVO if the unit has not been misused or tampered with during the warranty period. Normal maintenance items and disposable components as outlined in this manual are not covered by this warranty. Shipping charges, if any, shall be paid by the purchaser.



evo Medical Solutions

2636 289th Place

Adel, IA 50003

515.993.5001

515.993.4172 f

800.759.3038 (toll free)